

W I D E R A N G E
Western **SOUND** *Electric* **SYSTEM**
The NEW VOICE of ACTION

300B Vacuum Tube

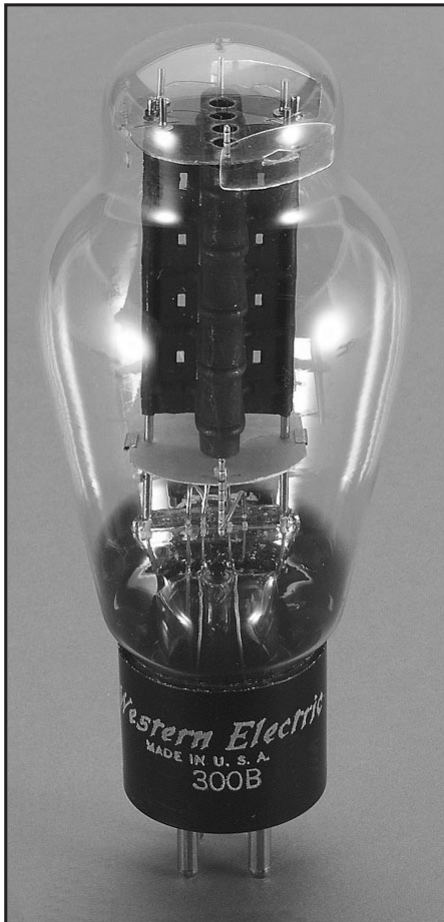

Classification

Moderate power, filamentary triodes for Class A service

Application

Audio-frequency amplifier in positions where power outputs of approximately ten watts or less are required at relatively low plate voltages.

Dimensions

Dimensions, outline diagrams of the tubes and bases, and the arrangement of electrode connections to the base terminals are shown in Figures 1 and 2.

Base and Mounting

These vacuum tubes employ medium, four-pin thrust type bases suitable for use in Western Electric 143B or similar sockets. The 300B tube has the bayonet pin so located that it may also be mounted in a Western Electric 100M, 115B or similar socket.

The tubes may be mounted in either a vertical or horizontal position. If mounted in a horizontal position, the plane of the filament, which is indicated in Figure 2, should be vertical.

Average Direct Interelectrode Capacitances

Grid to plate 15 $\mu\mu$ f.
 Grid to filament 9 $\mu\mu$ f.
 Plate to filament 4.3 $\mu\mu$ f.

Filament Rating

Filament voltage ... 5.0 volts, a.c. or d.c.
 Nominal filament current... 1.2 amperes

The filaments of these tubes are designed to operate on a voltage basis and should be operated at as near the rated voltage as possible. When alternating current is used for heating the filament, the grid and plate returns should be connected to a center tap on the secondary of the filament transformer.

Characteristics

Average characteristics -

($E_f = 5.0$ volts, a.c., $E_b = 300$ volts and $E_c = -61$ volts).

Plate current 60 milliamperes
 Amplification factor 3.85
 Plate resistance 700 ohms
 Grid to plate
 transconductance 5500 micromhos

Limiting Operating Conditions for Safe Operation

Not simultaneous ratings

Maximum plate voltage 450 volts
 Maximum plate dissipation 40 watts
 Maximum plate current of average tube for fixed grid bias 70 milliamperes
 Maximum plate current for manually adjusted grid bias or self-biasing circuit. 100 milliamperes

Recommended Operating Conditions

Recommended and maximum conditions for alternating-current filament supply are given in the table. Recommended conditions or others of no greater severity should be selected in preference to maximum conditions wherever possible. The life of the tube at maximum operating conditions will be shorter than at the recommended conditions.

Where it is necessary to operate the tube at or near the maximum plate current of 100 milliamperes, provision should be made for adjusting the grid bias of each tube independently, so that the maximum safe plate current will not be exceeded in any tube. Alternatively, a self-biasing circuit may be used, in which the grid bias for the tube is obtained from the voltage drop produced by the plate current of that tube flowing through a resistance.

Where it is necessary to use a fixed grid bias, the plate current of the average tube should be limited to a maximum value of 70 milliamperes, so that tubes having plate currents higher than the average will not exceed the maximum safe plate current.

300B Vacuum Tube

Power Output and Distortion

Performance data including power output, second and third harmonic levels for a number of operating conditions are given in the table.

The variation of power output and harmonic levels with load resistance for several values of operating plate current are shown in Figures 7, 8 and 9, for a plate voltage of 350 volts.

The peak value of the sinusoidal input voltage, E_{gm} , which gives the indicated power output, P_m and harmonic levels, F_{2m} and F_{3m} for each point in both the curves and the table, is numerically equal to the grid biasing voltage at that point. For a smaller input voltage E_g , the approximate levels may be computed from the following relations.

$$P = P_m \left(\frac{E_g}{E_{gm}} \right)^2$$

$$F_2 = F_{2m} + 20 \log_{10} \frac{E_g}{E_{gm}}$$

$$F_3 = F_{3m} + 40 \log_{10} \frac{E_g}{E_{gm}}$$

Plate Voltage Volts	Grid Bias Volts	Plate Current Milliamps	Load Resistance Ohms	Power Output Watts	2nd Harmonic db	3rd Harmonic db
200	-42	30	2000	3.0	20	31
200	-39	40	2500	2.6	26	38
200	-37	50	2500	2.5	30	45
250	-55	30	2000	4.9	18	27
250	-55	30	4500	3.2	27	40
250	-52	40	3000	4.0	26	36
250	-50	50	2500	4.4	26	39
250	-48	60	2000	4.7	26	38
250	-48	60	2700	4.1	30	45
250	-45	80	1500	5.0	26	41
300	-65	40	2500	6.7	20	30
300	-63	50	2000	7.2	21	29
300	-63	50	3000	6.1	26	37
300	-61	60	2400	6.6	26	37
300	-61	60	3400	5.6	30	44
300	-58	80	1700	7.5	26	37
350	-76	50	3600	7.8	26	38
350	-76	50	5000	6.2	30	45
350	-74	60	2000	10.2	21	30
350	-74	60	3000	8.3	26	38
350	-74	60	4000	7.0	30	44
350	-71	80	2200	9.6	26	39
400	-91	40	5000	8.4	26	37
400	-89	50	3000	11.5	21	31
400	-89	50	4000	9.4	25	38
400	-87	60	3500	10.5	26	38
400	-87	60	5000	8.3	30	46
400	-84	80	2500	12.5	25	37
450	-104	40	6000	9.5	26	38
450	-102	50	5000	10.7	27	39
450	-102	50	6500	9.0	30	45
450	-100	60	4000	12.5	26	38
450	-100	60	5500	10.1	30	44
450	-97	80	2000	17.8	21	30
450	-97	80	3000	14.6	26	37
450	-97	80	4500	11.5	31	45

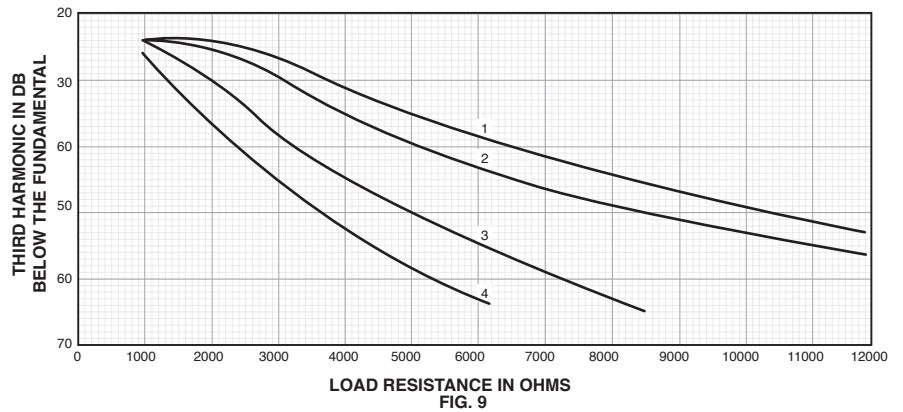
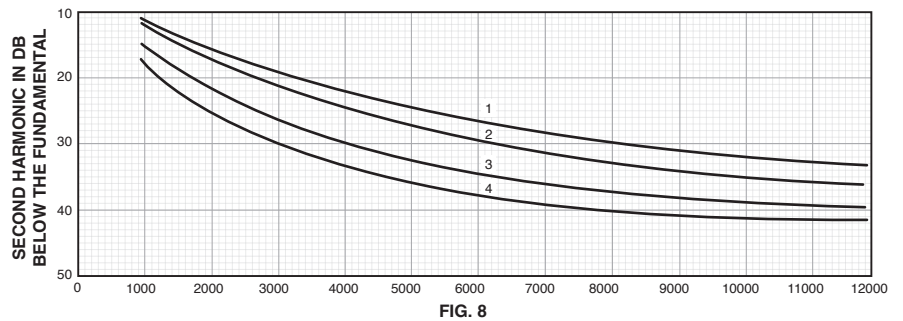
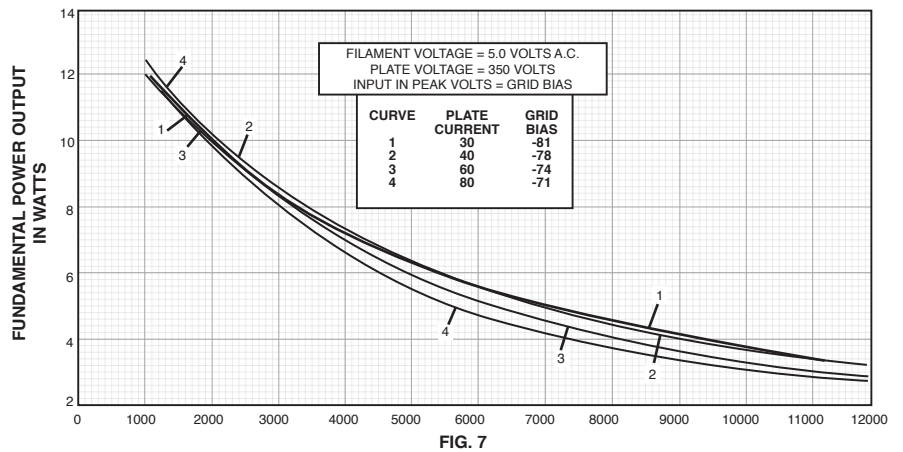

300B Vacuum Tube

Characteristics

Plate-current characteristics for a typical tube are shown in Figure 3 as functions of grid bias, for alternating-current filament supply. The corresponding amplification-factor, plate-resistance, and transconductance characteristics are given in Figures 4, 5 and 6, respectively. When direct-current filament supply is used, and the grid and plate returns are connected to the negative end of the filament, the same characteristics are applicable if 3.5 is subtracted from the numerical value of each grid bias.

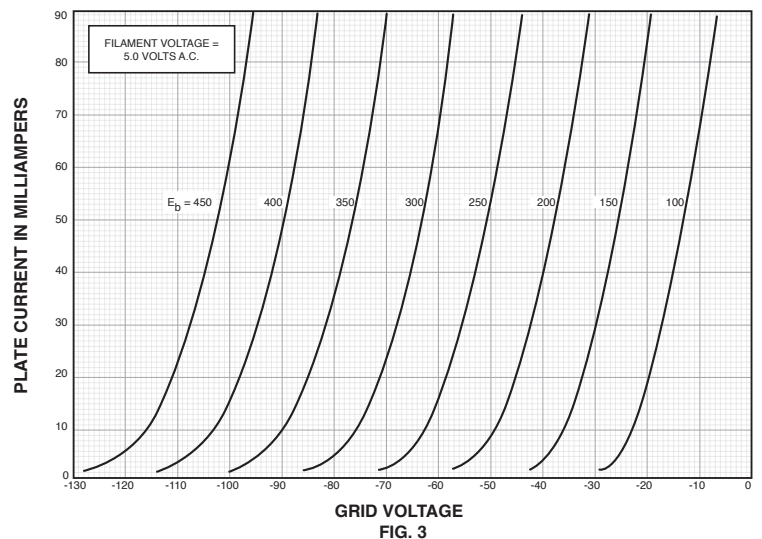
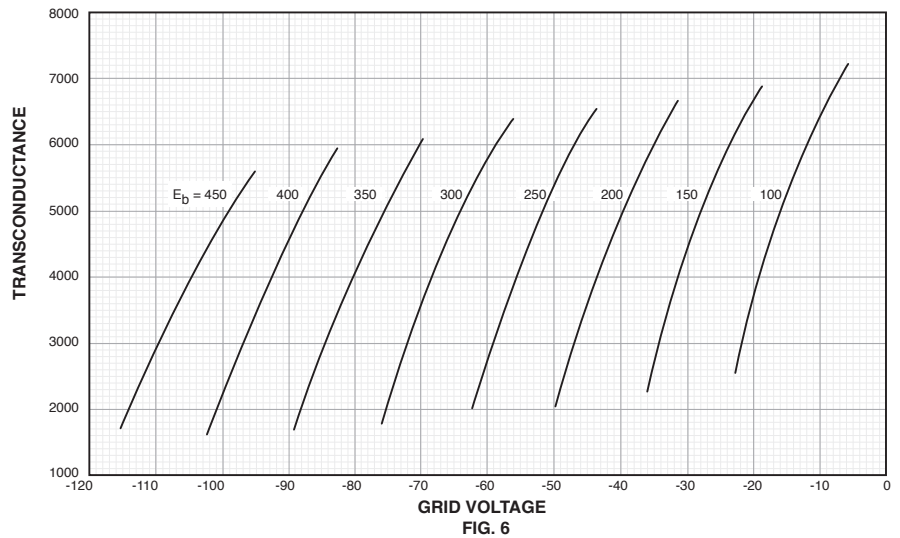
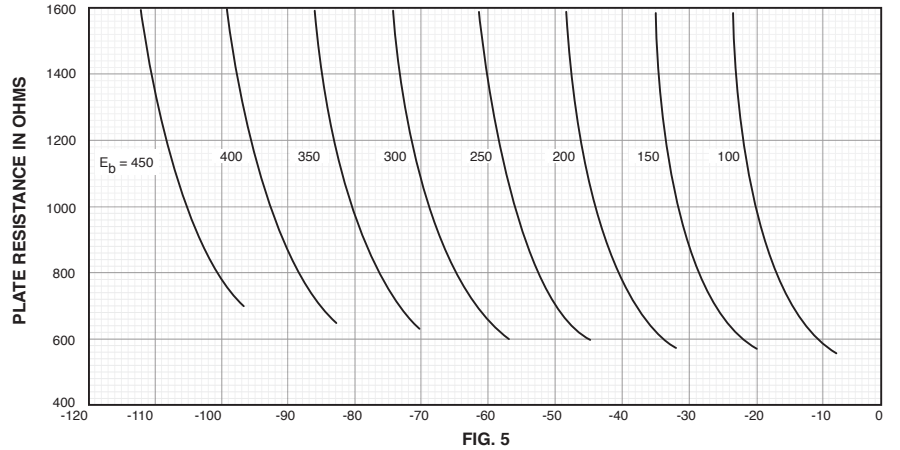
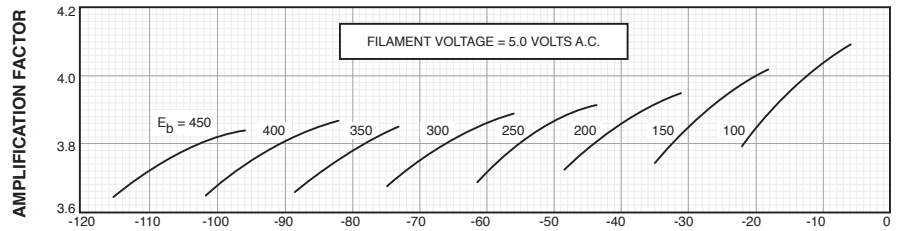

300B Vacuum Tube

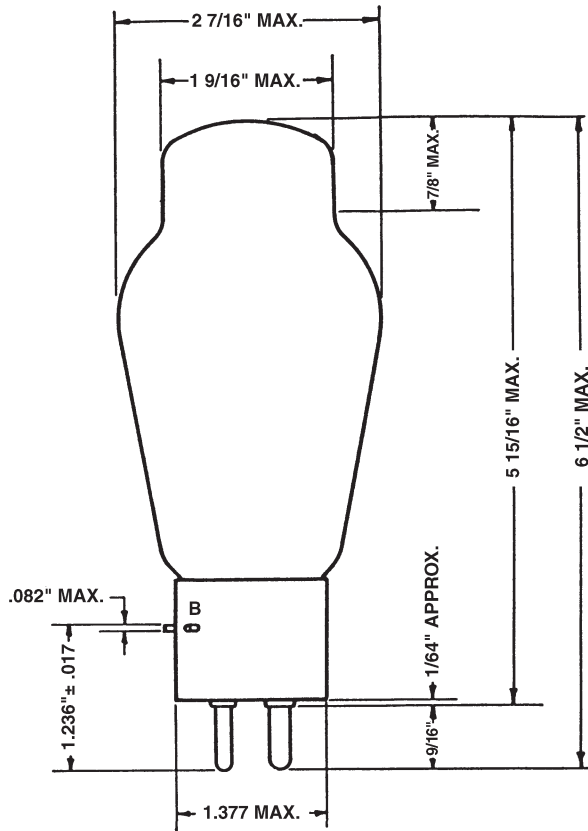

FIG. 1

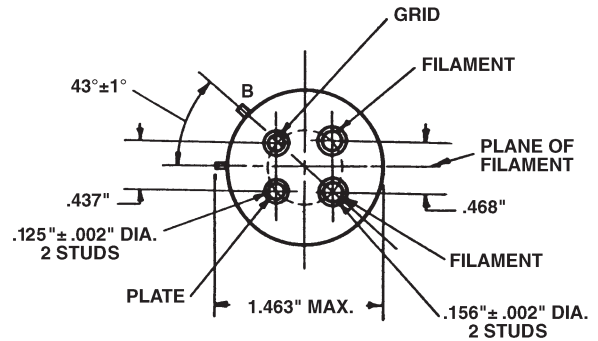

FIG. 2

B—LOCATION OF BAYONET PIN FOR 300B TUBE

Ordering Information

(Order by Code and Comcode)

Electron Tubes

Code	Application	Comcode
300B	Moderate Power Triode	100792522

For more information please contact a Western Electric™ Sales Representative.

Western Electric™
410 Chickamauga Avenue, Suite 300
Rossville, GA

Phone: 404-352-2000
www.westernelectric.com

Western Electric™ High Fidelity products are marked worldwide Exclusively by Western Electric™

Western Electric™ Electron tubes are manufactured in the U.S.A. developments of Bell Telephone Laboratories.

Western Electric™

Western Electric™ reserves the right to make changes to the product(s) described in this document in the interest of improving internal design, operational function and/or reliability. Western Electric™ assumes no liability which may occur due to use or application of the product(s) or the circuit layouts described herein.

Copyright © 2016 Western Electric™ Export Corporation.
All Rights Reserved. Printed in the U.S.A.



Western Electric™ Export Corporation
410 Chickamauga Avenue, Suite 300
Rossville, Georgia 30741

Phone: 404-352-2000
www.westernelectric.com

Western Electric™

Western Electric™ is a trademark of Western Electric™ Export Corporation.
Copyright © 2016 Western Electric Export Corporation.
All Rights Reserved. Printed in the U.S.A. • Rev. 8/16